

Technologies

**Fibre Channel
Product Overview**

Analyzer to *Simulyzer*[™]

www.aviftech.com



Avionics Interface Technologies Fibre Channel Product Overview

GENERAL FEATURES

The Avionics Interface Technologies family of Fibre Channel test and simulation products are used in applications ranging from analyzers and simulators to verification and validation tools. All Fibre Channel products utilize multiple processors with large onboard RAM. A PowerPC processor runs the driver software onboard, minimizing host CPU interaction. This enables autonomous operation with minimal interaction during time-critical test and simulation applications.

The AIT Fibre Channel product uses our *Simulyzer™* technology that enables the hardware to perform Fibre Channel data generation and Fibre Channel monitoring on the same physical port. AIT Fibre Channel products are available in PCI and PXIe for test applications.

All AIT Fibre Channel products include full-function device driver software for the most popular operating systems, an application interface supporting multiple development environments, including C, C++, and LabView. A comprehensive set of source code examples is included.

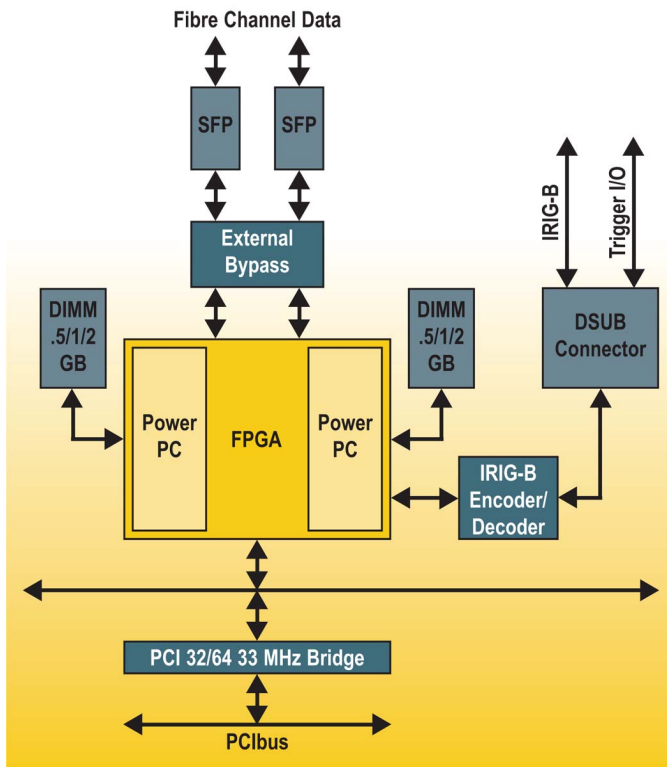

DUAL PORT DATA GENERATOR

- ♦ Generation of Fibre Channel primitives/frames at full line rates
- ♦ Simulate Fibre Channel end-devices
- ♦ Full error injection on any frame header or payload parameter
- ♦ Work simultaneously with dual-port Analyzer

DUAL PORT ANALYZER

- ♦ Full chronological monitoring of all Fibre Channel ports to eight nanosecond resolution
- ♦ Full error detection
- ♦ Work simultaneously with Data Generator
- ♦ Complex triggering
- ♦ Message filter and selective capture

DATA CORRUPTOR™

- ♦ Dynamically change Fibre Channel data in a link
- ♦ Emulate a network delay, or introduce jitter in the Fibre Channel link

IRIG-B TIME CODE ENCODER/DECODER

- ♦ All boards include IRIG-B input for synchronization to a common time source
- ♦ IRIG-B encoder with sinusoidal output and free-wheeling mode

PHYSICAL BUS REPLAY

- ♦ Electronically reconstruct previously recorded Fibre Channel to an output port

LIVE DATA CAPTURE

- ♦ Live capture of Fibre Channel data in real-time
- ♦ Current value monitoring displays Fibre Channel frames in real-time

APG-FC4

- ◆ Two Fibre Channel ports
- ◆ Supports standard line rates of 1, 2, and 4 Gbps and user-defined rates between 1 and 4 Gbps
- ◆ 312mm x 107mm full length PCI format
- ◆ PCI-x Rev 2.3 compliant, bus master & slave
- ◆ 33/66/100/133 MHz, 32/64-bit, 5V and 3.3V compatible

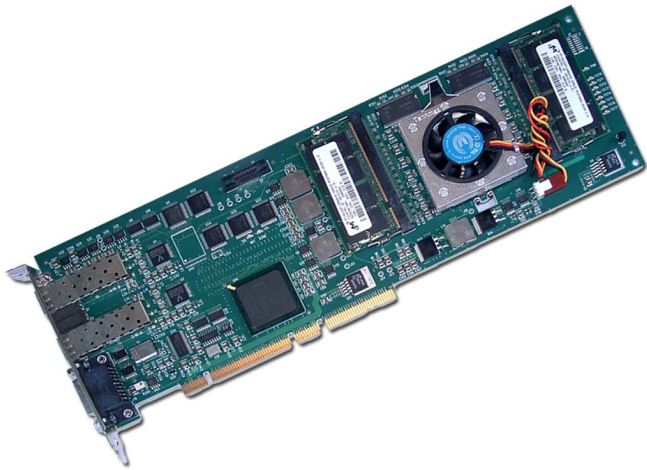

PXI-CFC4X-2

- ◆ Two Fibre Channel ports
- ◆ Supports PTP, Switched Fabric, and Arbitrated Loop topologies
- ◆ In-line Port Configuration for Transparent Analyzer
- ◆ *fcXplorer* Windows-based FC Simulator and Analyzer Test Software

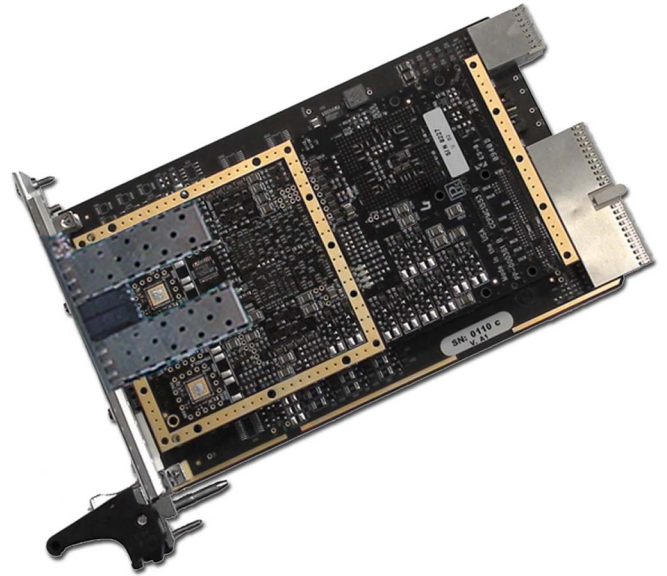

Photo Credit: Lockheed Martin

APPLICATION INTERFACE

The application interface for Fibre Channel is an ANSI C library for the AIT Fibre Channel APG-FC4 *Simulyzer*[™] boards. The application interface simplifies software development with its intuitive functions.

The application interface supports multiple languages:

- ♦ C
- ♦ C++
- ♦ LabVIEW

multiple operating systems:

- ♦ Windows
- ♦ Linux
- ♦ VxWorks
- ♦ LynxOS
- ♦ Integrity

and multiple development environments:

- ♦ MSVC 6.0
- ♦ MSVS 2005/2008 C++
- ♦ LabVIEW

Included with the application interface are several C++ programs (delivered as source code) which perform various functions. The Fibre Channel sample programs utilizes the application interface functions. The FCX functions can be used by the application developer to easily program APG-FC4 *Simulyzer*[™] setup for transmission, reception, monitor, filter, trigger, and status.

FCXPLOER

- ♦ Optional Analyzer, test, and visualization software
- ♦ Graphical User Interface (GUI) (Windows) to control Fibre Channel boards without programming
- ♦ Setup configuration of the link
- ♦ ACSII file used to control the generation of customized Fibre Channel frames
- ♦ Decoding of Fibre Channel frames in FC-1, FC-2, FC-4, and customized decodes
- ♦ Optional *Data Corruptor*[™] feature

fcXplorer is a Windows-based Fibre Channel analyzer software program for use with AIT boards. The intuitive GUI provides the ability to easily setup the Fibre Channel transmit ports and monitoring of the Fibre Channel ports without programming. *fcXplorer* supports all of the APG-FC4 *Simulyzer*[™] board operations including recording, physical replay, triggering, and filter setup.

